

## Consumer Frequently Asked Questions

### 1. How does a By-pass HEPA Air Filtration System operate and what are the benefits?

A By-pass HEPA Air Filtration System is installed on to the cold air return duct of the air handling system. Approximately 30% of the air traveling through the cold air return is diverted and pulled through the HEPA system. The clean air is then exhausted back into the main air-handling duct and re-circulates through the home. As air is continuously passed through the filter, particulate, biologicals and chemicals are stripped away and held in the filters.

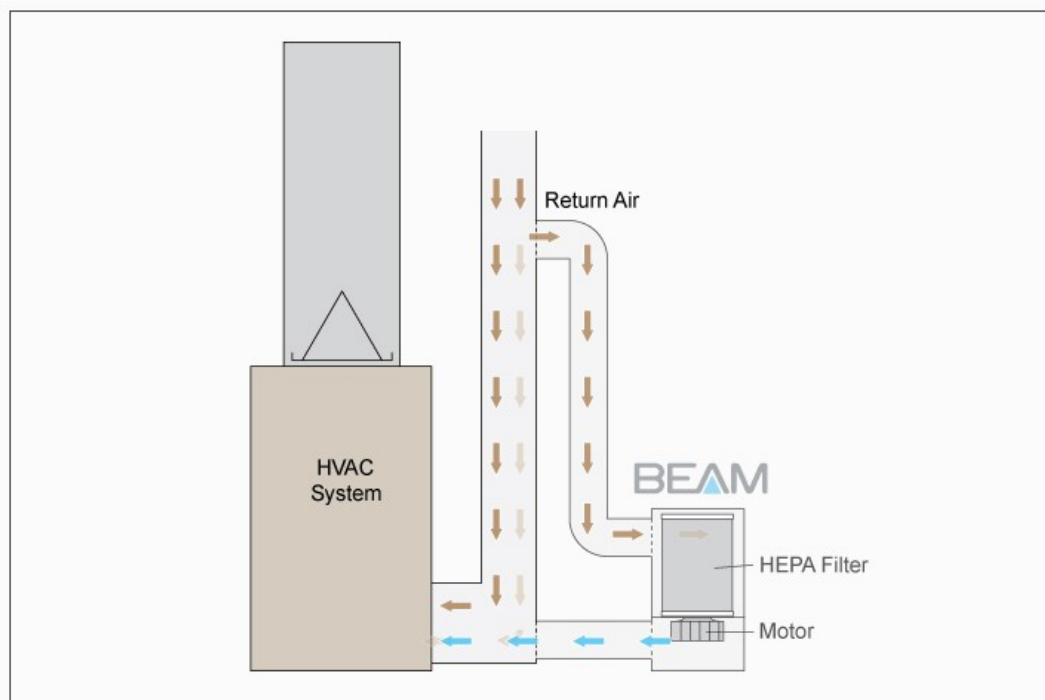

### 2. How does a By-pass HEPA Air Filtration System affect air-pressure in my HVAC air handling system?

The best part about installing a By-pass system is that it will not void the warranty on the furnace or air handling system. By diverting only a portion of the air traveling through the air-handling system, there is no adjustment to the air pressure in the air-handling system and thus no interruption to the function of the air-handler or furnace.

### 3. Is it alright to continuously run the HVAC air handling system?

It is recommended to have the air-handling fan run continuously to achieve the most efficient operation of the air-handler or furnace. Continuously circulating the air in a home will reduce the effects of stratification. Stratification occurs when air becomes stagnant and all the hot or warm air remains in the top of a room and all the cool air settles in the bottom of a room. This settling of air will cause the thermostat to read inaccurately and the air-handler will run when it is not really needed. If the air-handling fan is running, air in the home will be "mixed" and temperature will be dispersed evenly. The thermostat will then provide more accurate results and heating and cooling will require less energy.

Running the air-handler fan all the time will also provide the most efficient operation of the HEPA system. Although the HEPA system runs independently from the air-handler and has its own fan, the air-handler has the capability to draw air from the far ends of a home and bring that air to the HEPA system for cleaning.

#### 4. How does the 3-stage filtration work?

Air pollution can be divided into 3 basic groups: Particulate, Biologicals and Volatile Organic Compounds. The BEAM HEPA Air Filtration Systems have 3 stages of filtration designed to capture pollutants that make up each category of air pollution.

- The Prefilter (first stage) filter captures large particulate such as dust and sloughed-off skin. By capturing the large particulate, the Prefilter protects the HEPA filter allowing it to efficiently filter out much smaller particulate.
- The HEPA filter (second stage) captures 99.97% of airborne particulate at 0.3 micron in size. This size of particle makes up approximately 85% of particles in the air which can include: pollen, dust-mite carcasses and feces, pet dander, cigarette smoke and Biologicals, such as: viruses, mold spores, bacteria and fungi. Particles that are 0.3 micron are invisible to the human eye and small enough to travel into the lungs. In an environment with a particle count of 1,000,000 per cubic foot at 0.3 micron, the HEPA filter will reduce that number to 300 particles per cubic foot.
- The Inner Carbon Blanket (third stage filter) captures Volatile Organic Compounds. These are chemicals in the gas state. In the home, they are often released from paints, perfumes, plastic, furniture, cleaning products and many others. The Carbon Blanket acts as a sponge that soaks up gaseous chemicals as air travels through the filter.



#### 5. What is the significance of V.O.C.s in terms of IAQ?

Years of industrial development have created a great unknown in the form of Volatile Organic Compounds (V.O.C.s). Basic science shows us that under the right conditions chemicals react with other chemicals to form new combinations. Cars, manufacturing, various waste and many other functions of modern society release millions of chemicals into the atmosphere everyday. These chemicals are free to roam and be consumed by humans. Although direct results of the intake of chemicals cannot be predicted, it is well known that many chemicals do not have a positive impact on the human system. Everyday items in the home can create a toxic soup; furniture, carpets, cleaning products, perfume, cigarette smoke, paints and plastic can all release V.O.C.s into the indoor ambient air. Once released into the air, these chemical gases

can also react with one another to create more harmful chemicals. A BEAM HEPA system is a great way to reduce the level of gaseous chemicals present in the home.

**6. What sets these systems apart from all the other products available?**

HEPA is the most scientifically studied filter system in the world today and that is why it is used in Operating Room filtration across North America (hospitals) and in industrial clean rooms as the system of choice and the most failsafe air cleaning method. HEPA systems when properly designed and built, provide the best removal of particulates and pathogens. HEPA is basically the only system of removal that has a strict standard of accomplishment referenced as 99.97% removal of particulate at 0.3 microns. When a system actually accomplishes removing particles at the defined standard, a significant reduction in airborne pollution is achieved.

**7. Does the Beam HEPA system utilize and/or emit OZONE?**

The BEAM HEPA systems are superior to other methods of filtration by accurately achieving HEPA standard. Additionally, these systems do not create any OZONE, IONS or V.O.C.s. Other methods of filtration, such as: Ion Generators, Electrostatic Filters, Ozone Generators and UV Lights may emit V.O.C.s and alter or create new chemicals with their process of treating air. Ozone Generators create and emit harmful ozone into the air. Although Ozone will attack bacteria it doesn't stop there. It continues to attack all living tissue, including human lung tissue. HEPA filters employ simple technology to provide a safe, tried and proven method for cleaning the air. HEPA filters have been in use with over 50 years of positive results.

**8. What if I do not have a central HVAC system?**

The Installed systems can still be employed in a home or space without an HVAC system or air-handler. There are several installation options. The most common are shown below:

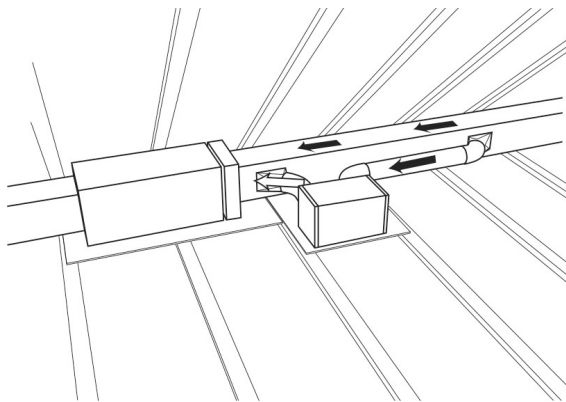

Attic Installation

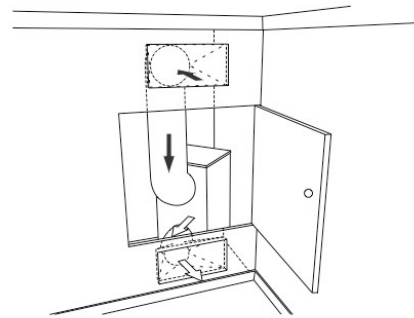

Closet Installation

If you are not comfortable with any of the above installation options, one or more portables systems can provide an alternative sizing solution.